

PRODUCT NUMBER

10056844-YXXXLF

LEAD FREE, RoHS COMPATIBLE, NOTE 8.
PACKAGING SEE NOTE 5

PLATING

- 1 - 0.76µm GOLD/GXT (PdNi WITH GOLD FLASH) ON CONTACT AREA
- 2µm MIN MATTE TIN ON TAILS.
- 1.27µm NICKEL MIN UNDERPLATING

STYLE	SIZE
06	2x03
08	2x04
10	2x05
14	2x07
16	2x08
20	2x10
26	2x13
30	2x15
34	2x17
40	2x20

NOTES:

- 1 - HOUSING MATERIAL: HIGH TEMPERATURE THERMOPLASTIC, UL94 V-0 COLOR BLACK.
- 2 - CONTACT MATERIAL: COPPER ALLOY
- 3 - MINIMUM PUSH OUT FORCE OF PIN IN EITHER DIRECTION : 20N BEFORE SOLDERING.
- 4 - TO DETERMINE DIMENSIONS :
N = NUMBER OF POSITIONS PER ROW
EXAMPLE : 8 POS N x 2.54 = 20.32mm
- 5 - PACKAGING.
A = TAPE & REEL WITH PICK-UP CAP.
SEE TA-893 FOR PRODUCT AVAILABILITY.
= TUBE WITHOUT PICK-UP CAP
- 6 - NO LEFT POLARIZATION ON STYLE 06, 08, 10, 14.
- 7 - NO RIGHT POLARIZATION ON STYLE 06, 08.
- 8. RoHS COMPLIANT & COMPATIBLE PRODUCT SPECIFICATIONS
 - a - PLATING:
 - "LF" MEANS THE PRODUCT IS LEAD-FREE AND RoHS COMPLIANT
 - 2µm MINIMUM MATTE TIN ON TAILS OVER 1.27µm MINIMUM NICKEL UNDERPLATE.
 - b - THIS PRODUCT MEETS EUROPEAN UNION DIRECTIVES AND OTHER COUNTRY REGULATIONS AS PER GS-22-008.
 - c - MANUFACTURING PROCESS COMPATIBILITY
 - THE HOUSING WILL WITHSTAND EXPOSURE TO 260° PEAK TEMPERATURE FOR 10-30 SECONDS IN A CONVECTION INFRA-RED OR VAPOR PHASE REFLOW OVEN.
 - PHASE REFLOW OVEN.

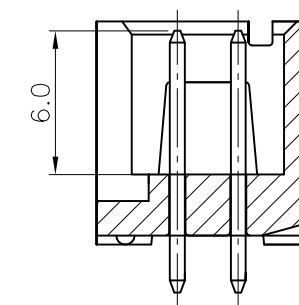
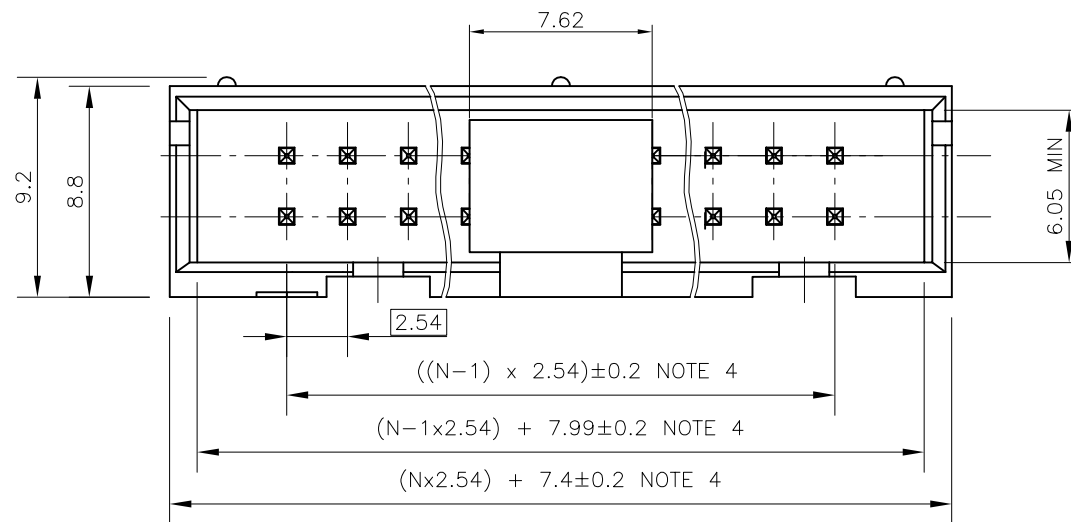

SECTION A-A
WITHOUT CAP

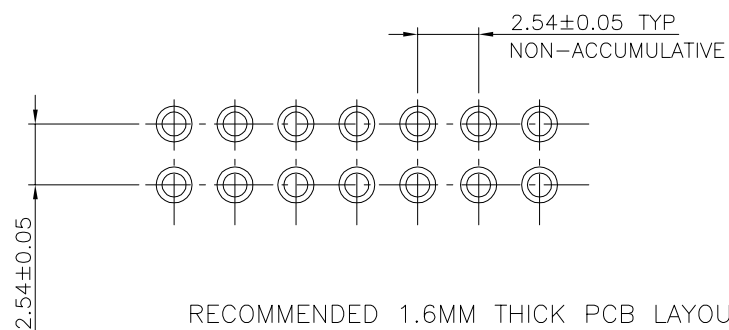
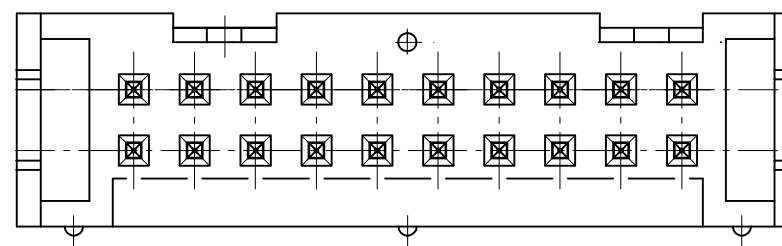
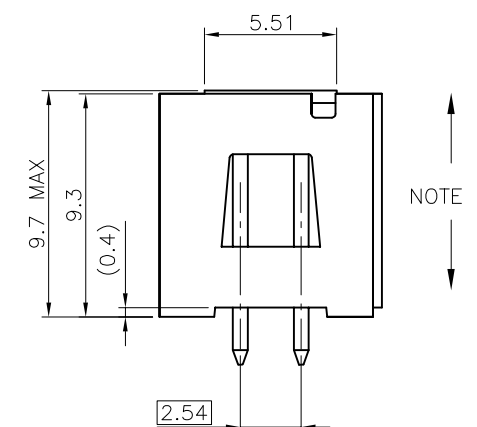
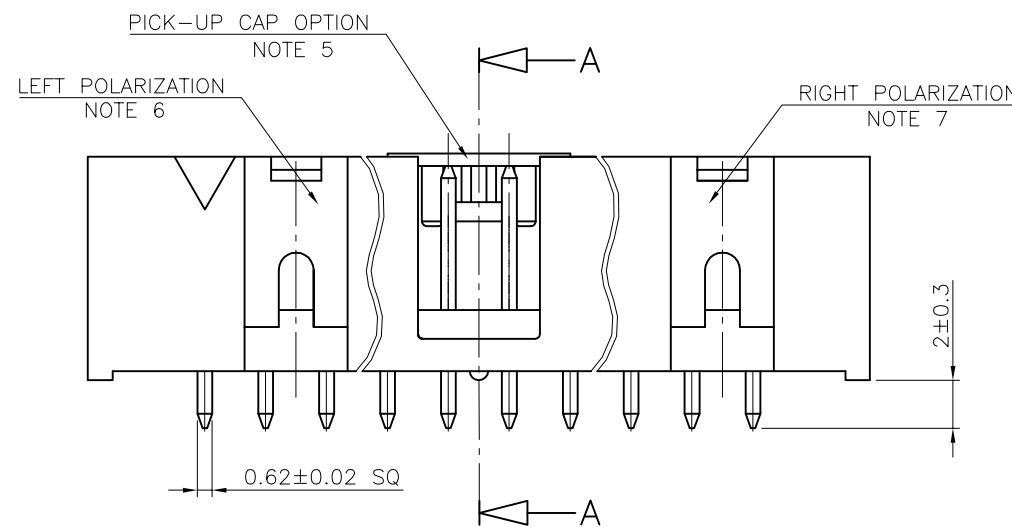

RECOMMENDED 1.6MM THICK PCB LAYOUT,
STENCIL DESIGN RECOMMENDATIONS AS PER TA-894

mat'l. code		surface		tolerance		projection		product family		
NOTES 1, 2		ISO 1302		ISO 406 ISO 1101				QKIE HDR		
ltr	ecn no	dr	date	tolerances unless otherwise specified		mm		title		
A	F06-0239	LMU	06.07.17	angles	.x ± 0.3			QKIE HEADER		
B	F06-0335	LMU	06.12.08	linear	.xx ± 0.15			LOW PROFILE PIN IN PASTE		
C	F07-0192	LMU	07.05.22		.xxx ± 0.05	scale 1:1		dwg no sheet 1 of 1 size		
D	F07-0198	LMU	07.05.30	dr	LMU	05.05.30			10056844 A3	
E	F08-0146	YOY	08.04.11	enr	JCO	06.07.17			type CUSTOMER Drawing	
				chr						
				appd	J COMPAGNON	06.07.17				
sheet index	revision sheet									



Copyright FCI